

# TRONIX ELECTRONIC BALLASTS USER'S MANUAL

The Tronix Electronic Ballast is a radical improvement over the ordinary magnetic choke-type ballast. Its features include starting mode reliability, longer life span for lamps, power savings, absence of starter, ease of installation and maintenance. Residential, commercial and industrial users get the full satisfaction and service that they deserve.

## I. ADVANTAGES:

### ***Energy Saving Device***

Gives 35-55% energy savings on your monthly electric lighting bill

### ***Longer Life-span for Fluorescent Lamps***

The removal of start-up stress and a more efficient frequency of operation (>300khz) extend your lamp life up to three times

### ***Built-in Protection / No Overheating***

Has a built-in overload protection unit and thermal circuit breaker and it saves air conditioning costs and lessens generator capacity requirements

### ***Brighter Lamp Output***

Flickering frequency is at 40-50 KHz which cannot be detected by human eyes, it is then eliminated to increase brilliance

### ***Instant Start / No Starter Required***

Equipped with an instant start feature for fluorescent lamp when the power is switched on. Since it does not require starters, it increases the reliability of the fluorescent lamp's starting mode

### ***High Power Factor***

High-power factor type ballast. Power factor is also on the capacitive side which allows power factor correction for industrial users whose plant loading is almost inductive. The need for power factor correction capacitors are minimized, if not eliminated

## II. TECHNICAL SPECIFICATIONS:

	1 x 20W	1 x 40W	2 x 40W	2 x 20W
Input Voltage	220 VAC	220 VAC	220 VAC	220 VAC
Max Current	0.13 Amp	0.20 Amp	0.29 Amp	0.19 Amp
Power Factor	>.96	>.96	>.96	>.96
THD	<25%	<25%	<20%	<20%
Dimension	5.2 x 4.2 x 13.5 cm	5.2 x 4.2 x 13.5 cm	6 x 4.4 x 54.8 cm	6 x 4.4 x 54.8 cm
Voltage Variation	180 – 235 VAC	180 – 235 VAC	180 – 220 VAC	180 – 220 VAC
Warranty	3 Years	3 Years	3 Years	3 Years

*\* Features and models are subject to change without prior notice*

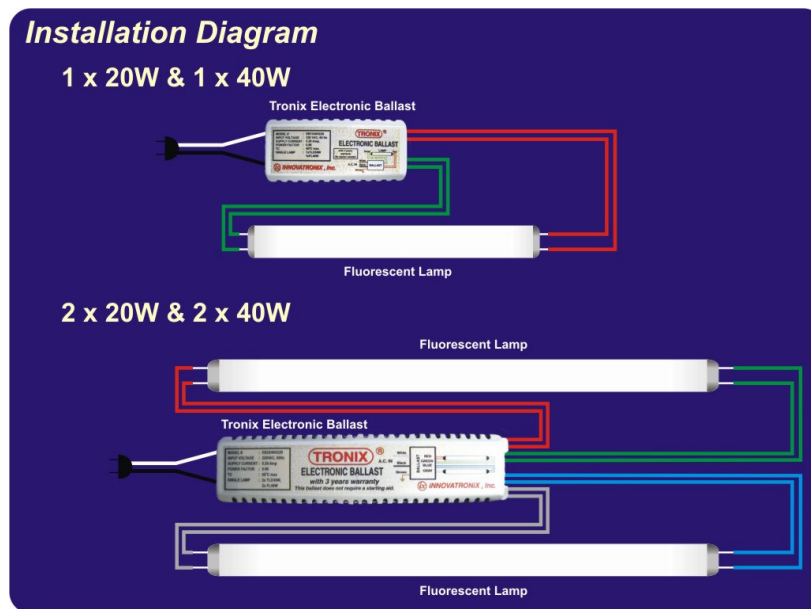

**Figure 1. Electronic ballast installation diagram**

### **Available Models:**

1. EB 1 x 20W – 200V
2. EB 1 x 40W – 220V
3. EB 1 x 20W – 110V
4. EB 1 x 40W – 110V
5. EB 2 x 20W – 220V
6. EB 2 x 40W – 220V
7. EB 2 x 20W – 110V

### III. PRODUCT WARRANTY STATEMENT

The **Tronix Electronic Ballast** is covered by a three year-warranty. Within this period, Innovatronix, Inc. will repair the item at no charge or if necessary replace defective parts. The warranty only covers failures due to manufacturing defects and workmanship; hence, breakdown of the unit due to gross abuse is not covered by the warranty.

This limited warranty extends only to the original consumer and is not transferable. Warranty registration is not required. Warranty is applicable if and only if the product is completely and correctly assembled, the product is used under normal conditions for its intended purpose, and received all necessary maintenance.

Parts and models are subject to change without prior notice.

## CONTACT US

Our customer service department is open Mondays thru Saturdays (except last Saturday of the month), 8:00am to 5:00pm to help you with any problems that may occur.

Call us: (632) 6451592 / (632) 6456124  
09236576946 (Sun Cellular)

Email us: [marketing@innovatronix.com](mailto:marketing@innovatronix.com)  
[www.innovatronix.com](http://www.innovatronix.com)

Antipolo City, Philippines